

MSH12TN MSH15TN MSH17TN MSH12TN - U1 MSH15TN - U1 MSH17TN - U1 Unit: inch

INDOOR UNIT

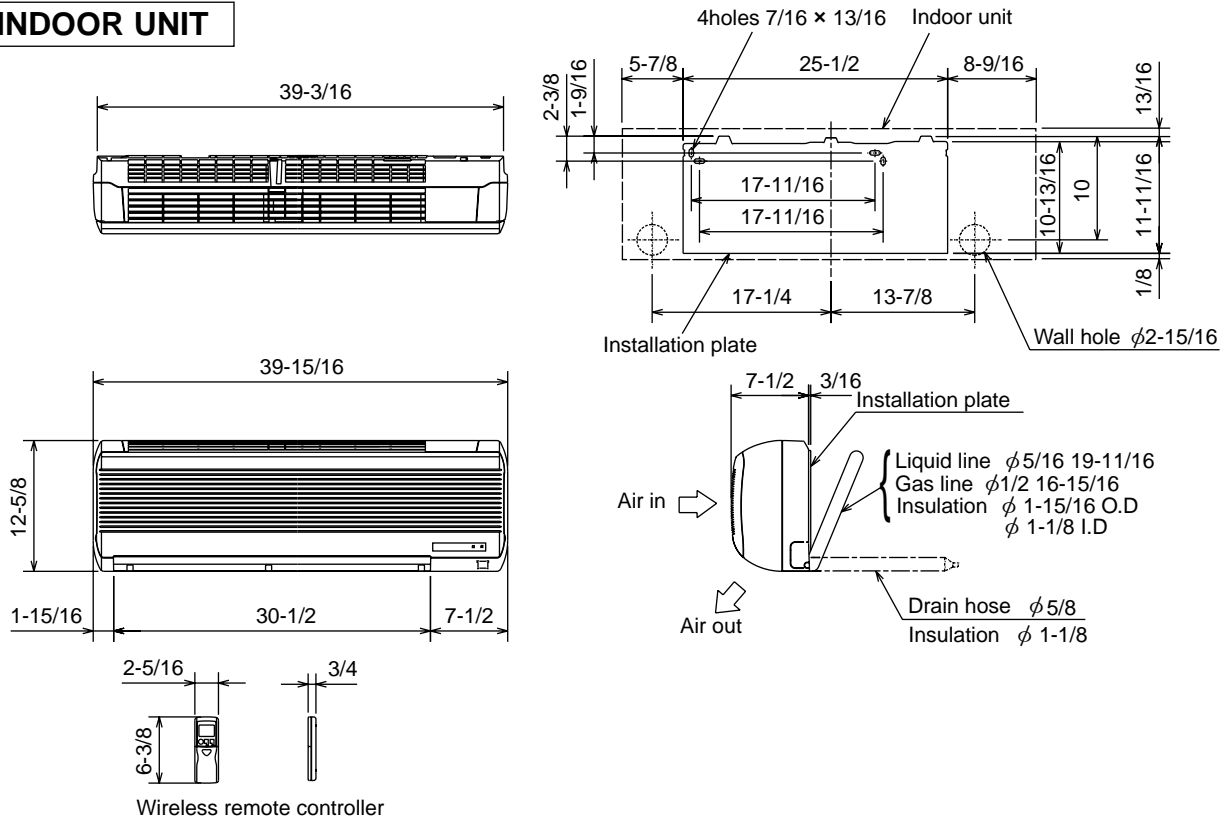

MUH15TN MUH15TN - U1
OUTDOOR UNIT

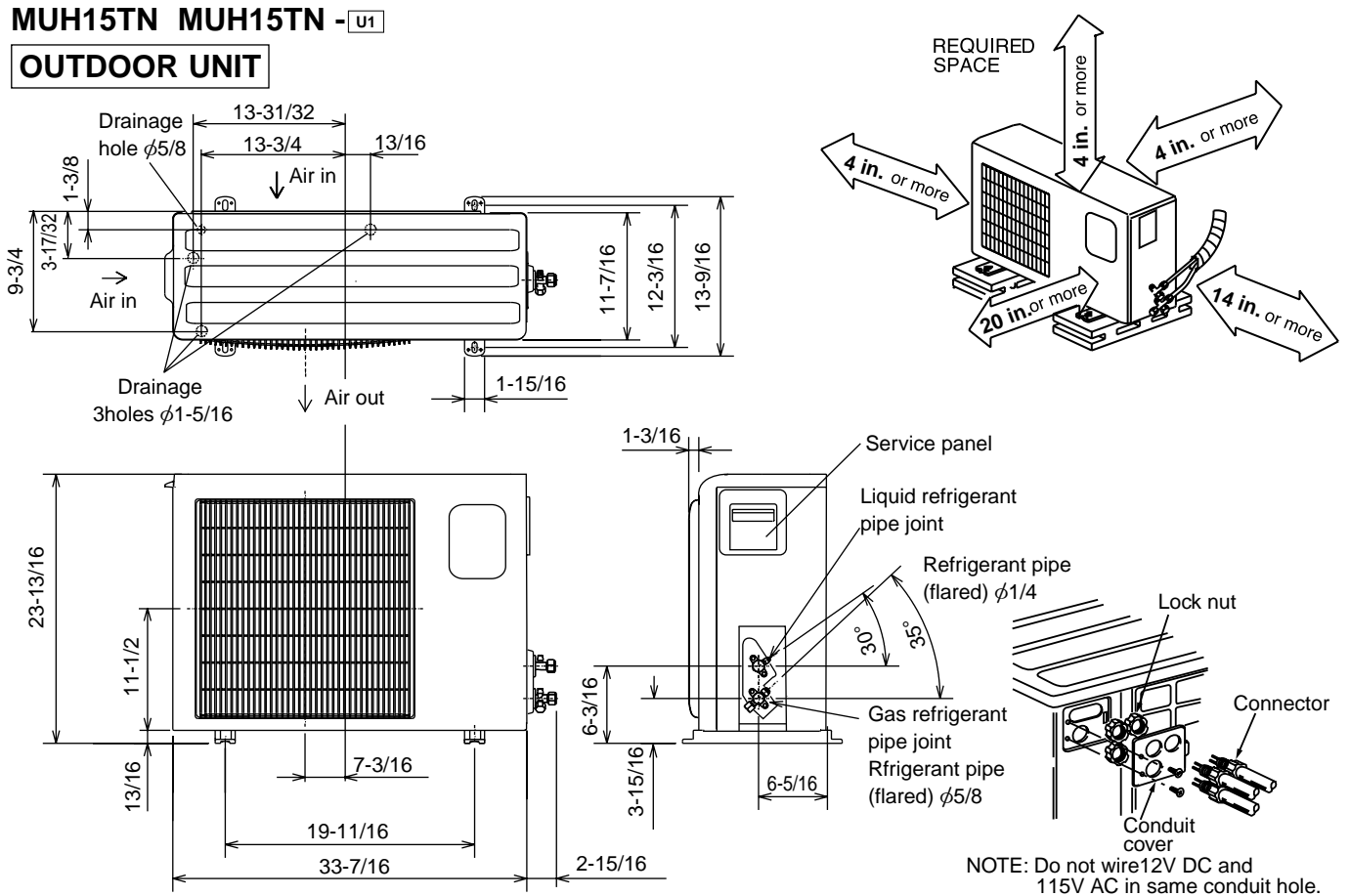



Model			MSH12TN MSH12TN - [U1]		MSH15TN MSH15TN - [U1]		
Item		Unit	Cooling	Heating	Cooling	Heating	
Total	Capacity	Btu / h	12,600/12,900	13,000/13,500	14,300/14,600	14,500/14,800	
	SHF	—	0.71	—	0.65	—	
	Input	kW	1.28/1.31	1.18/1.25	1.35/1.38	1.25/1.30	
Electrical circuit	Indoor unit		MSH12TN MSH12TN - [U1]		MSH15TN MSH15TN - [U1]		
	Power supply (V, phase, Hz)		115, 1, 60		115, 1, 60		
	Input	kW	0.047		0.047		
	Fan motor current	A	0.41		0.41		
	Aux. heater current	A	—		—		
	Outdoor unit		MUH12TN MUH12TN - [U1]		MUH15TN MUH15TN - [U1]		
	Power supply (V, phase, Hz)		208/230, 1, 60		208/230, 1, 60		
	Input	kW	1.233/1.263	1.133/1.203	1.303/1.333	1.203/1.253	
	Comp. current	A	5.74/5.21	5.24/5.01	5.91/5.41	5.41/5.11	
	Fan motor current	A	0.36/0.39		0.49		
Refrigerant circuit	Condensing pressure	PSIG	259	203	246	230	
	Suction pressure	PSIG	84	58	80	57	
	Discharge temperature	°F	194	158	146	158	
	Condensing temperature	°F	120	103	112	108	
	Suction temperature	°F	67	36	58	33	
	Comp. shell bottom temp	°F	177	144	161	143	
	Ref. pipe length	ft.	25		25		
	Refrigerant charge (R22)	—	2 lb. 12 oz.		3 lb. 3 oz.		
Indoor unit	Intake air temperature	DB	°F	80	70	80	70
		WB	°F	67	60	67	60
	Discharge air temperature	DB	°F	57	100	57	107
		WB	°F	56	—	54	—
	Fan speed (High)	rpm	1,200		1,200		
	Airflow (High)	CFM	388(Wet)	452(Dry)	367(Wet)	452(Dry)	
Outdoor unit	Intake air temperature	DB	°F	95	47	95	47
		WB	°F	—	43	—	43
	Fan speed	rpm	700/740		830/900		
	Airflow	CFM	974/1,034		1,288/1,394		

POWER SUPPLY

MSH12/15TN MSH12/15TN - [U1]

•Both wirings can be applied to all MODELS.

INDOOR UNIT 115V 60Hz 1φ, 2wires

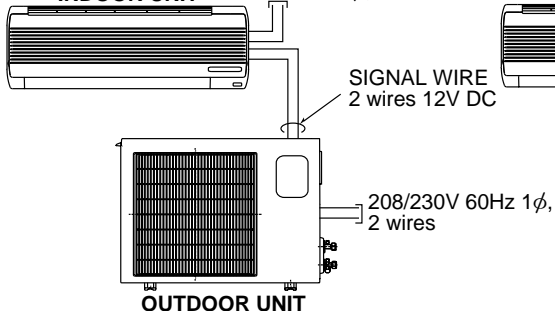

INDOOR UNIT

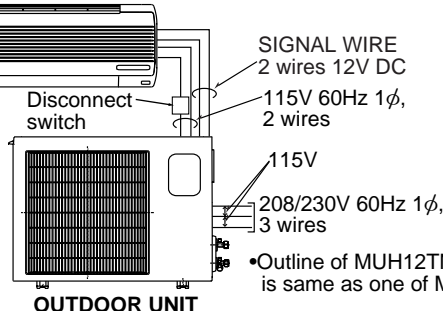

[Control voltage]

Power supply voltage to serial signal circuit is 12V DC. Voltage between [] - and [] + on in-out terminal block will be 12V DC peak voltage.

•Outline of MUH12TN(-[U1]) is same as one of MUH09TW.